



BELLE
LIGHT
CONSTRUCTION
EQUIPMENT

FLOATS & TOOLS



- Spare Parts Book

6



Contents

Slab Surface Floating	2
Choosing a Float	2
Placer and Rake	2
Technical Data	2
Description	3
Operating Instructions	4
Assembly Instructions	4
Warranty	5

Belle Group reserves the right to change machine specification without prior notice or obligation.



Slab Surface Floating

The screeding process will leave slight ripples on the concrete surface. For some applications this is acceptable as the texture can increase the effective slip resistance on slopes and ramps.

Screeding with vibration also causes a less desirable effect. The intensity of vibration at the surface can cause a separation of the aggregate and cement. The heavier particles including the sand sink below the surface leaving a thin layer of brittle cement on the surface. This is often referred to as 'laitance' or 'fat'

When the concrete is still in a plastic state the surface can be re-mixed and surface irregularities smoothed out using a float.

This process is quick and easy if the right tools are used. A wide float blade is pushed and pulled across the slab using a long handle so the operator can work the slab from the sides.

Floats can also incorporate a brush to reintroduce a texture to the concrete surface.



Choosing A Float

Choice is often down to contractor preference. The well know 'Easy float' is often requested but all floats do a similar job. The higher weight of a steel float enables a slab to be worked slightly later in the curing process and some contractors prefer more rounded edges. All the Belle floats are fitted with twist to tilt brackets on the blade so the blade can be angled easily for pushing and pulling across the slab.

3 handle sections are included to allow reach of over 5.5m, additional handles can be added if required.



Placer and Rake

These are not floats but as hand tools they are included in this section.

These tools speed up the placing of concrete. They are designed to allow operators to push and pull wet concrete to the right levels, unlike a shovel which is designed for lifting. A concrete rake or placer can be up to five times faster and a lot less effort than a shovel.



Technical Data

Model	Width (mm)	Depth (mm)	Total Handle Length (m)	Weight (Kg)
Easy Bull Float (c/w Swivel and Handles)	1200	200	5.4	9.6
Easy Bull Float (c/w Swivel, No Handles)	1200	200	N/A	6
Big Blue Float (c/w Swivel and Handles)	1200	300	5.4	14.7
Big Blue Float (c/w Swivel, No Handles)	1200	300	N/A	11.1
Fresno Broom (c/w Swivel and Handles)	900	220	5.4	8.4
Fresno Broom (c/w Swivel, No Handles)	900	220	N/A	8.4
Concrete Placer	495	115	N/A	2
Concrete Rake	570	130	N/A	2

The Floats and Hand Tools are used to smooth and improve the surface of the concrete. Just twist the long handle and swivel head angles the blade for pushing and pulling across the surface.

Below are all models which are included in our Floats and Hand Tools range:-

Floats

Bull Float

The Bull Float includes a lightweight Magnesium Alloy blade with reinforcement to prevent warping. There are rounded corners on the float head to reduce 'track marks' when floating and the robust heavy duty design is ideal for tough site conditions and rental fleets.



Big Blue

The Big Blue includes a tempered 'blue' steel blade that achieves an ultra fine finish. Extra rounded corners on the float head prevent 'track marks' when floating and the 'sprung' steel blade glides over concrete even when still reasonably wet.



Fresno Broom

The Fresno Broom is a special combination float for applying a consistent brushed 'non slip' finish to concrete. The broom attachment is 'floated' across the concrete surface using a steel blade. It is pushed over the concrete to improve surface consistency and then pulled back across to apply the brush finish. A Softer brush is also available as a spare part.



Hand Tools

Concrete Placer

The Concrete Placer is a special 'rake' style tool that makes it easy to drag concrete when slab pouring. It includes a Double edge blade - One side is for moving high volumes of material and the other for small surface adjustments. This reduces the effort required compared to using conventional rakes and shovels. Can also be used as a small surface tamper.



Concrete Rake

The Concrete Rake is a special 'rake' style tool that makes it easy to drag concrete when slab pouring. It includes a Double edge blade - One side is for moving high volumes of material and the other for small surface adjustments. This reduces the effort required compared to using conventional rakes and shovels. Can also be used as a small surface tamper.



Fresno Broom Finishing

- Pour the slab
- Strike off with a screed
- Bull float
- Wait for the bleed water to evaporate (although with low water-cement ratio exterior concrete with the proper amount of air, there might not be much bleed water)
- Cure the concrete - You can (and must) cure broom-finished concrete with sheets of polyethylene or by spraying on curing compound. For plain grey concrete, a curing agent with some color (typically white) in it helps you to see where it's been applied. The color dissipates after a few weeks. For decorative concrete, use a cure & seal. Don't forget the curing!

A good broom finish is something of an art. You can even create decorative effects by running the broom texture in various directions. Typically the broom should be run from side to side of the concrete without stopping.

Assembly Instructions - Fresno Broom

To attach the Fresno Broom to the Float, please carry out the following procedure. This must be completed for each side of the Float.

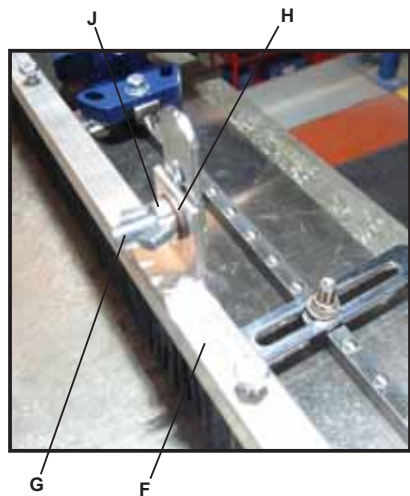
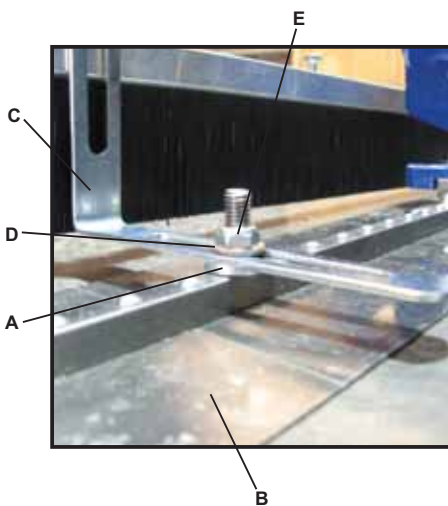

1. Place 2 x Washers (A) over the Stud on the Float (B) and then place the Bracket (C) over the Stud and on top of the Washers. Position the Bracket where you like, depending on how close you want the Broom (F) to be to the Float.
2. Slide another Washer (D) over the Stud so that it sits on top of the Bracket. Tighten the Bracket to the Float using the Nut (E)
3. Place the Broom (F) up to the other side of the Bracket and slide the Bolt (G) through the 2 holes. Again, position the Bracket where you like, depending on how close you want the Broom (F) to be to the concrete surface.
4. Slide a Washer (H) over the Bolt and tighten with the Wing Nut (J)

Your new Belle Group 'Floats and Hand Tools' are warranted to the original purchaser for a period of one-year (12 months) from the original date of purchase. The Belle Group warranty is against defects in design, materials and workmanship.

The following are not covered under the Belle Group warranty:

1. Damage caused by abuse, misuse, dropping or other similar damage caused by or as a result of failure to follow assembly, operation or user maintenance instructions.
2. Alterations, additions or repairs carried out by persons other than Belle Group or their recognised agents.
3. Transportation or shipment costs to and from Belle Group or their recognised agents, for repair or assessment against a warranty claim, on any machine.
4. Materials and/or labour costs to renew, repair or replace components due to fair wear and tear.

Belle Group and/or their recognised agents, directors, employees or insurers will not be held liable for consequential or other damages, losses or expenses in connection with or by reason of or the inability to use the machine for any purpose.

Warranty Claims

All warranty claims should firstly be directed to Belle Group, either by telephone, by Fax, by Email, or in writing.

For warranty claims:

Belle Group Warranty Department,
Sheen, Nr. Buxton
Derbyshire
SK17 0EU
England.

Tel : +44 (0)1298 84606

Fax : +44 (0)1298 84722

Email : warranty@belle-group.co.uk

Floats

Fresno Broom

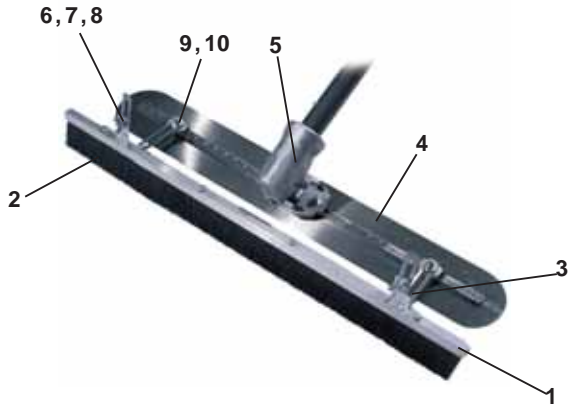

Bull Float

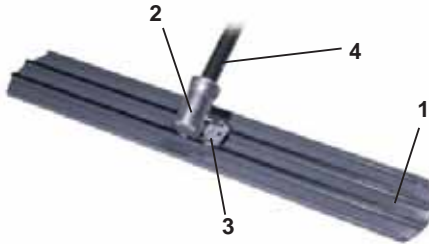

Big Blue

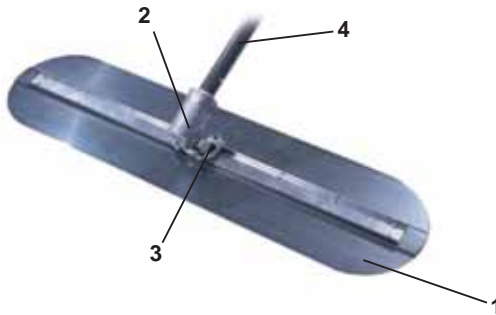

Floats

Fresno Broom

Item (1) Number	Part No. (2)	Description (3)	Quantity (4)
1	50003	Replacement Strip	1
2	50008	Brush c/w Mounting Brackets	1
3	50005	L -Shaped Mounting Brackets	2
4	50006	Spare Blade	1
5	50000	Knuckle Head	1
6	00.0.861	Coach Bolt	2
7	01.0.500	Wing Nut	2
8	05.7.060	Repair Washer	2
9	05.7.068	Washer	4
10	01.4.100	Nyloc Nut	4
	50010	Single Handle	1
	50011	Set of 3 Handles	1
	50041	Fresno Broom Brush and Blade	1
	50012	Handle Clip	1
	50013	Male Connector (c/w Handle Clip)	1

Bull Float

Item (1) Number	Part No. (2)	Description (3)	Quantity (4)
1	50021	Bull Float Blade	1
2	50000	Knuckle Head	1
3	02.4.037	Setscrew	2
4	50010	Single Handle	1
	50011	Set of 3 Handles	1
	50012	Handle Clip	1
	50013	Male Connector (c/w Handle Clip)	1

Big Blue

Item (1) Number	Part No. (2)	Description (3)	Quantity (4)
1	50031	Big Blue Blade	1
2	50000	Knuckle Head	1
3	01.4.002	Nut	2
4	50010	Single Handle	1
	50011	Set of 3 Handles	1
	50012	Handle Clip	1
	50013	Male Connector (c/w Handle Clip)	1

(1) Item Number / numero sur le schéma / número de la ilustración / número da ilustração / afbeeldingsnummer / tegningsnummeret / Teil-Nummer / numero dell'illustrazione

(2) Part Number / Numéro de référence de la pièce / número de pieza / número da parte / stuknummer / Styknummer / Nummer auf der Abbildung / numero di parte

(3) Description / Désignation / Descripción / Descrição / Omschrijving / Beskrivelse / Bezeichnung / Descrizione

(4) Quantity / Quantités / Cantidad / Cantidade / Hoeveelheid / Mengen / Mængde / Quantitá



BELLE
LIGHT
CONSTRUCTION
EQUIPMENT

ALTRAD BELLE
Sheen, Nr. Buxton, Derbyshire, SK17 0EU, GB
Tel. +44 (0)1298 84606 - Fax +44 (0)1298 84722 - Email: sales@altrad-belle.com
www.Altrad-Belle.com